



TDA7496L

LINEAR INTEGRATED CIRCUIT

2W+2W AMPLIFIER WITH DC VOLUME CONTROL

DESCRIPTION

The **UTC TDA7496L** is a class AB power amplifier with linear volume control, Stand-by and mute functions, it's mainly using for high quality sound, TV and Monitor applications.

FEATURES

- * Linear volume control, Stand-by and mute functions
- * Silent Turn On/Off
- * No boucherot cell
- * 2 x 2W output power: $R_L=8\Omega@THD=10\%$, $V_{CC}=14V$
- * No ST-BY RC input network
- * Internally Fixed Gain (Typ.=30dB)
- * Single supply (Max.=18V)
- * Soft clipping
- * Output DC Short Circuit protection when shorted to GND or V_{CC} .
- * Thermal shutdown
- * Variable output after volume control circuit

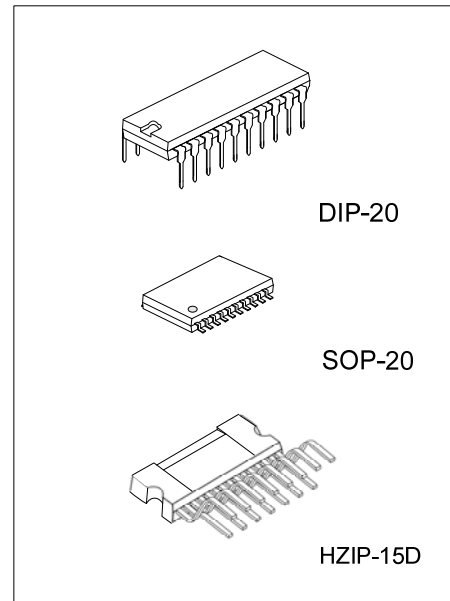

ORDERING INFORMATION

Ordering Number		Package	Packing
Lead Free	Halogen Free		
TDA7496LK-D20-T	TDA7496LG-D20-T	DIP-20	Tube
TDA7496LK-S20-R	TDA7496LG-S20-R	SOP-20	Tape Reel
TDA7496LK-J15-D-T	TDA7496LG-J15-D-T	HZIP-15D	Tube

<p>TDA7496LG-D20-T</p> <p>(1)Packing Type (2)Package Type (3)Green Package</p>	<p>(1) T: Tube, R: Tape Reel (2) D20: DIP-20, S20: SOP-20, J15-D:HZIP-15D (3) G: Halogen Free and Lead Free, K: Lead Free</p>
--	---

MARKING

Package	Marking
DIP-20	<p> UTC □□□□ → Date Code K: Lead Free TDA7496L □ → G: Halogen Free □□ → Lot Code </p>
SOP-20	<p> UTC □□□□ → Date Code K: Lead Free TDA7496L □ → G: Halogen Free □□ → Lot Code </p>
HZIP-15D	<p> UTC TDA7496L □ → K: Lead Free □□ → G: Halogen Free □□□□ → Data Code Lot Code ← 1 </p>

PIN CONFIGURATION

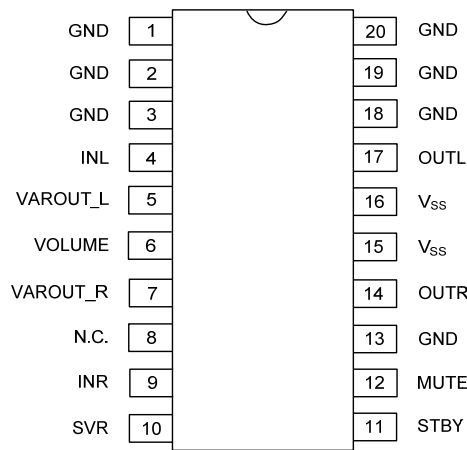

DIP-20/SOP-20

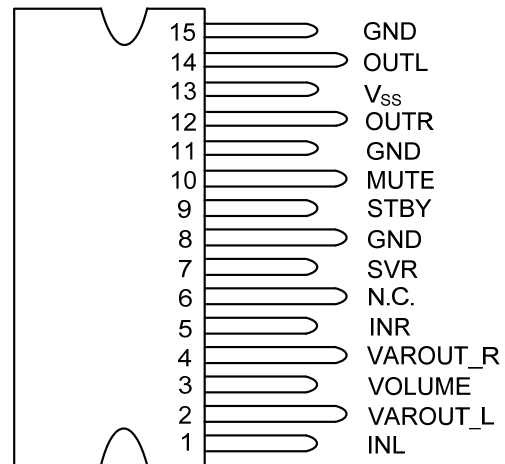

HZIP-15D

■ BLOCK DIAGRAM

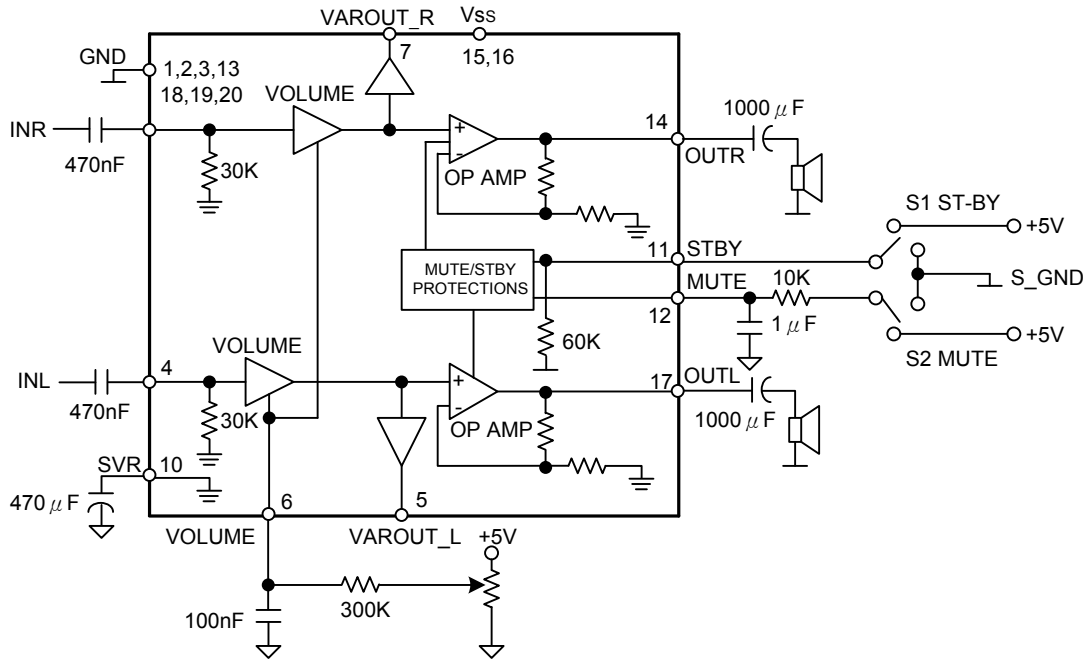

■ ABSOLUTE MAXIMUM RATINGS ($T_A=25^\circ\text{C}$, unless otherwise specified)

PARAMETER		SYMBOL	RATINGS	UNIT
DC Supply Voltage		V_{SS}	26	V
Maximum Input Voltage		V_{IN}	8	V
Volume CTRL DC Voltage		V_6	6	V
Power Dissipation	DIP-20($T_C=60^\circ\text{C}$)	P_D	6	W
	SOP-20		4	
	HZIP-15D		12.5	
Junction Temperature		T_J	+150	$^\circ\text{C}$
Ambient Operating Temperature		T_{OPR}	0 ~ +70	$^\circ\text{C}$
Storage Temperature		T_{STG}	-40 ~ +150	$^\circ\text{C}$

Note: Absolute maximum ratings are those values beyond which the device could be permanently damaged. Absolute maximum ratings are stress ratings only and functional device operation is not implied.

■ THERMAL DATA

PARAMETER		SYMBOL	RATINGS	UNIT
Junction to Ambient	DIP-20	θ_{JA}	50	$^\circ\text{C}/\text{W}$
	SOP-20		80	
	HZIP-15D		46	

■ ELECTRICAL CHARACTERISTICS (T_A=25°C, V_{SS}=14V, unless otherwise specified)

PARAMETER		SYMBOL	TEST CONDITION	MIN	TYP	MAX	UNIT
Supply Voltage Range		V _{SS}		10		18	V
Quiescent Current		I _Q			25	50	mA
Output DC Offset Referred to SVR Potential		DCVos	No Input Signal		200		mV
Quiescent Output Voltage		V _{OUT}			7		V
Output Power	THD=10%	P _{OUT}	R _L =8Ω	1.6	2		W
	THD=1%				1.3		
Total Harmonic Distortion		THD	G _V =30dB, P _{OUT} =1W, f=1KHz			0.4	%
Output Peak Current		I _{OUT(PEAK)}	(internally limited)	0.7	0.9		A
Input Signal		V _{IN}				2.8	V
Closed Loop Gain		G _V	V _{OL} Ctrl>4.5V	28.5	30	31.5	dB
Monitor Out Gain		G _{V(LINE)}	V _{OL} Ctrl>4.5V, Z _{LOAD} >30kΩ	-1.5	0	1.5	dB
Attenuation at Minimum Volume		Amin VoL	V _{OL} Ctrl<0.5V	80			dB
Bandwidth		BW			0.6		MHz
Total Output Noise	Volume	eN	f=20Hz to 22KHz		500	800	μV
	Attenuation		f=20Hz to 22KHz		100	250	
	Mute		f=20Hz to 22KHz		60	150	
Slew Rate		SR		5	8		V/μs
Input Resistance		R _{IN}		22.5	30		kΩ
Variable Output Resistance		R _{VAR(OUT)}			30	100	Ω
Variable Output Load		R _{LOAD(OUT)}		2			kΩ
Supply Voltage Rejection f=1kHz	Volume	SVR	CSVR=470μF, VRIP=1V	35	39		dB
	Attenuation			55	65		
Thermal Muting		TM			150		°C
Thermal Shut-down		T _S			160		°C
MUTE STAND-BY&INPUT SELECTION FUNCTIONS							
Stand-by ON Threshold		V _{ST(ON)}		3.5			V
Stand-by OFF Threshold		V _{ST(OFF)}				1.5	V
Mute ON Threshold		V _{M(ON)}		3.5			V
Mute OFF Threshold		V _{M(OFF)}				1.5	V
Quiescent Current@ Stand-by		I _{QST-BY}			0.6	1	mA
Mute Attenuation		AMUTE		50	65		dB
Stand-by bias current		I _{BIAS(ST-BY)}	Stand by on V _{ST-BY} =5V, V _{MUTE} =5V		80		μA
			Play or Mute	-20	-5		μA
Mute bias current		I _{BIAS(MUTE)}	Mute		1	5	μA
			Play		0.2	2	μA

■ APPLICATION SUGGESTIONS

The recommended values of the external components are those shown on the application circuit of figure 1. Different values can be used, the following table can help the designer.

Component	Suggestion Value	Purpose	Larger Than Suggestion	Smaller Than Suggestion
R1	300K	Volume control circuit	Larger volume regulation time	Smaller volume regulation time
R2	10K	Mute time constant	Larger mute on/off time	Smaller mute on/off time
P1	50K	Volume control circuit		
C1	1000 μ F	Supply voltage bypass		Danger of oscillation
C2	470nF	Input DC decoupling	Lower low frequency cutoff	Higher low frequency cutoff
C3	470nF	Input DC decoupling	Lower low frequency cutoff	Higher low frequency cutoff
C4	470 μ F	Ripple rejection	Better SVR	Worse SVR
C5	100nF	Volume control time Constant	Larger volume regulation time	Smaller volume regulation time
C6	1000 μ F	Output DC decoupling	Lower low frequency cutoff	Higher low frequency cutoff
C7	1 μ F	Mute time constant	Larger mute on/off time	Smaller mute on/off time
C8	1000 μ F	Output DC decoupling	Lower low frequency cutoff	Higher low frequency cutoff
C9	0.1 μ F	Supply voltage bypass		Danger of oscillation

TYPICAL APPLICATION CIRCUIT

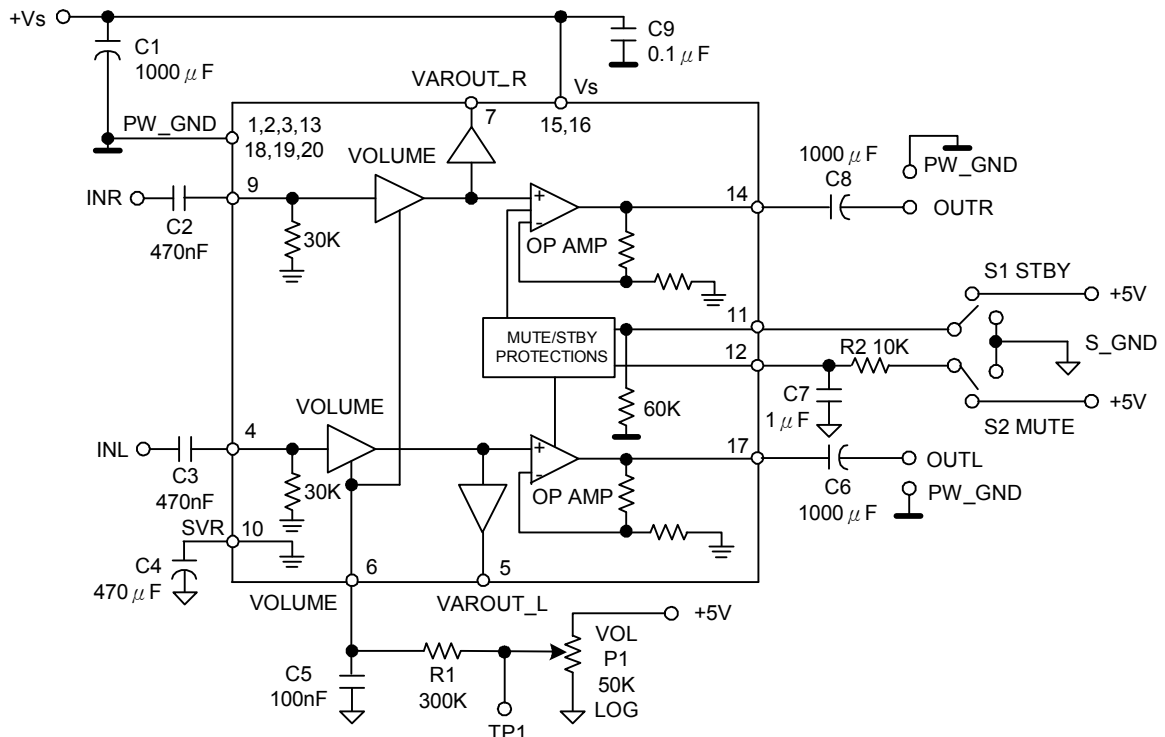

FIGURE 1. APPLICATION CIRCUIT

MUTE STAND-BY TRUTH TABLE

MUTE	ST-BY	OPERATING CONDITION
H	H	STANDBY
L	H	STANDBY
H	L	MUTE
L	L	PLAY

■ TURN ON/OFF SEQUENCES (FOR OPTIMIZING THE POP PERFORMANCES)

(A) USING MUTE AND STAND-BY FUNCTIONS

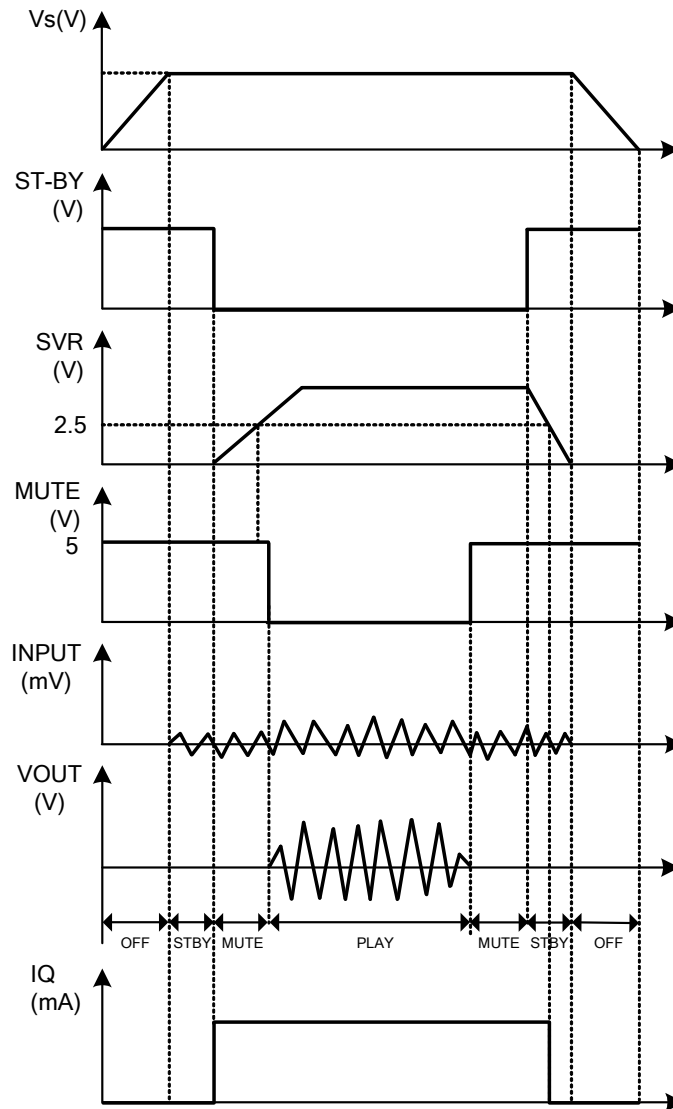

(B) The stand-by pin can be connected directly to Ground in the simply application.

During the ON/OFF transitions is recommend to respect the following conditions:

At the turn-on, when the SVR pin is higher than 2.5V, the transition mute - play can just be made.

At the turn-off, when the SVR pin is higher than 2.5V, the UTC TDA7496L can just be brought to mute from the play condition

FUNCTIONAL DESCRIPTION

PIN	FIGURE
SVR	<p>The diagram shows the internal circuit for the SVR pin. It features a differential amplifier structure. A 100 μA current source is connected to the base of a transistor. The circuit includes several resistors: 20K resistors, 6K resistors, 1K resistors, and 30K resistors. The output of the differential amplifier is split into two channels, OUT L and OUT R, each with a 30K feedback resistor. The SVR input is connected to the base of the differential pair.</p>
INL, INR	<p>The diagram shows the internal circuit for the INL and INR pins. It features a single input stage. A 500 μA current source is connected to the base of a transistor. The circuit includes a 6K resistor and a 30K resistor. The INL and INR inputs are connected to the base of the transistor. The SVR input is also connected to the base of the transistor.</p>
VAROUT_L, VAROUT_R	<p>The diagram shows the internal circuit for the VAROUT_L and VAROUT_R pins. It features a differential output stage. Two transistors are connected to the output nodes. A diode is connected to the base of one of the transistors. The VAROUT_L and VAROUT_R outputs are connected to the collector nodes. The Vss supply is connected to the base of the transistors.</p>

FUNCTIONAL DESCRIPTION(Cont.)

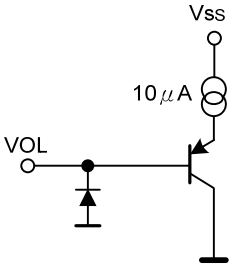
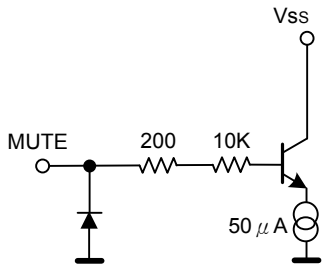
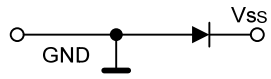
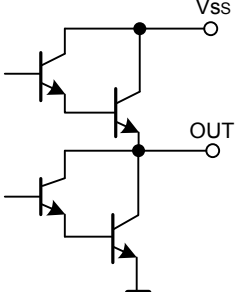
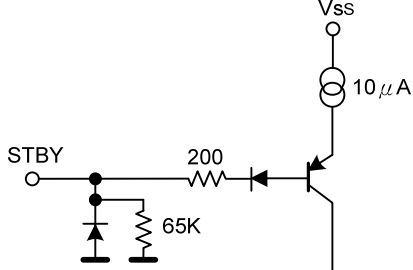
PIN	FIGURE
VOLUME	
MUTE	
PW_GND, S_GND	
VAROUT-L,V AROUT-R	
STBY	

TYPICAL CHARACTERISTICS

Quiescent current vs. Supply Voltage

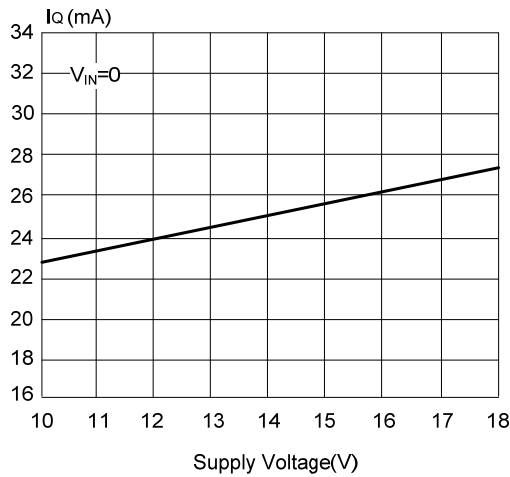

Output DC Voltage vs. Supply Voltage

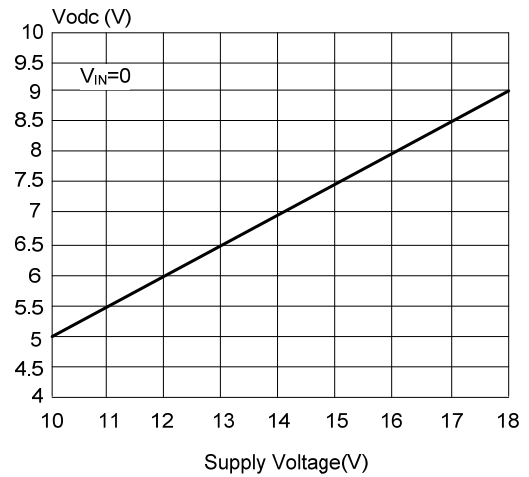

Output DC Offset vs. Supply Voltage

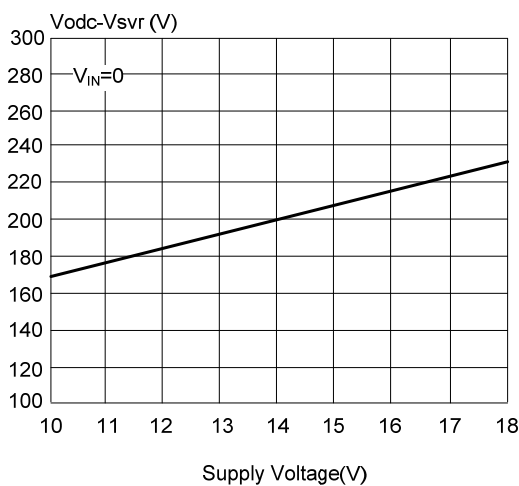

Output Power vs. Supply Voltage

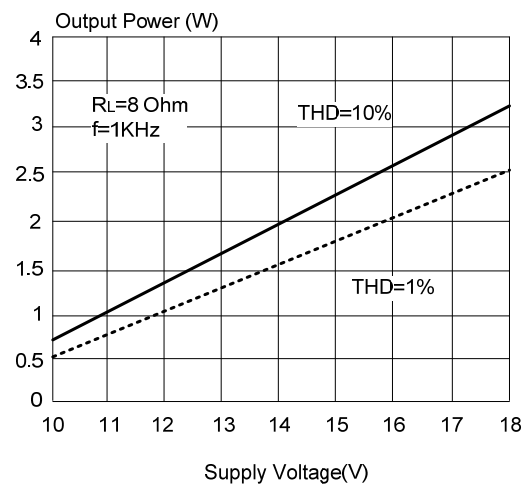

Distortion vs. Output Power

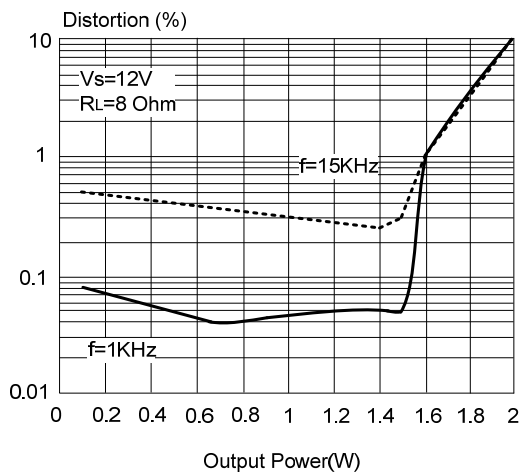

Closed Loop gain vs. Frequency

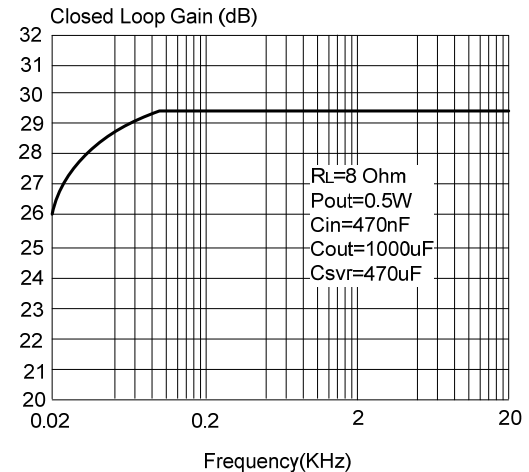

■ TYPICAL CHARACTERISTICS (Cont.)

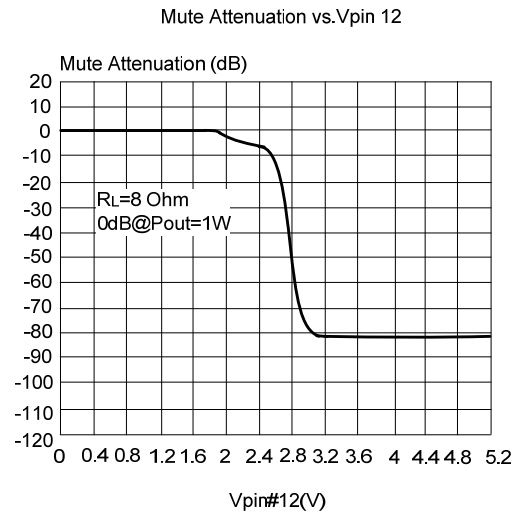
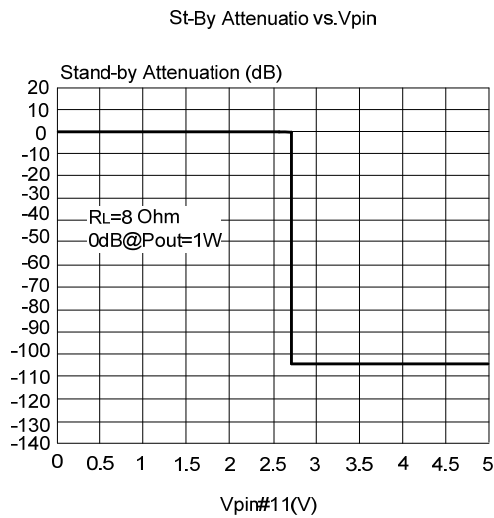

UTC assumes no responsibility for equipment failures that result from using products at values that exceed, even momentarily, rated values (such as maximum ratings, operating condition ranges, or other parameters) listed in products specifications of any and all UTC products described or contained herein. UTC products are not designed for use in life support appliances, devices or systems where malfunction of these products can be reasonably expected to result in personal injury. Reproduction in whole or in part is prohibited without the prior written consent of the copyright owner. UTC reserves the right to make changes to information published in this document, including without limitation specifications and product descriptions, at any time and without notice. This document supersedes and replaces all information supplied prior to the publication hereof.